



Scan the QR code to see the machine working



STONE

STONE IS ONE OF TOP AUTOMAZIONI'S ROBOTIC SOLUTIONS

INTEGRATED STORAGE ON A REVOLVING PALLET FOR THE LOADING/UNLOADING OF COMPONENTS

CAN BE COUPLED WITH ALL CNC MACHINES SUCH AS LATHES, MACHINING CENTERS, GRINDERS, ETC...



LAYOUT AND INSTALLATION

STONE is available in Central version and, based onto layout dimensions, can be paired with any CNC machine tool and adapt to the surrounding workplace. When STONE is not in use, Fanuc arm is positioned in such a way that leaves always free the machine working space. The peculiar design allows a fluent use of the HMI control panel, an easy access when setting up the CNC machine and a quick tooling's check.

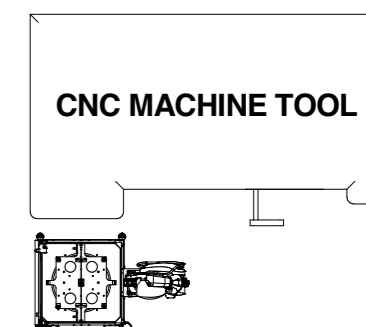
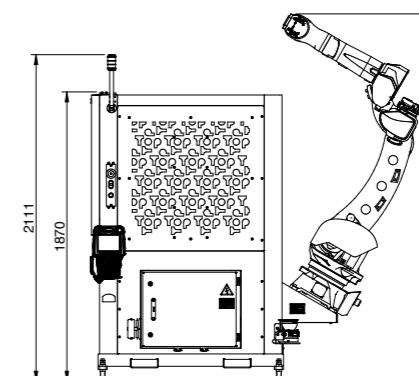
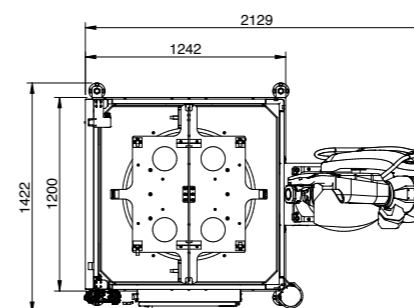
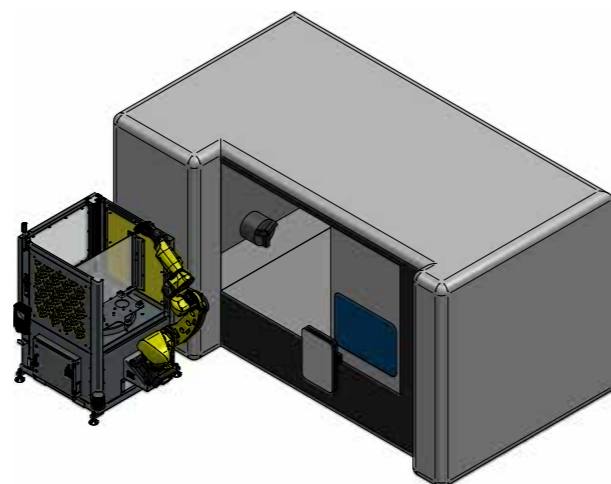

ROBOT FEATURES

- Fanuc M-20iD/25
- Payload 25 kg
- Max reach 2.000 mm, center tool point
- Max speed (J6) 720°/s
- Repeatability +/-0,02 mm
- Wrist protection class IP67
- Weight 250 Kg



STORAGE ON REVOLVING PALLET SYSTEM

- 2 trays (tailored on the workpieces shape and dimension)
- Tray dimensions 600x400 mm
- Max load each tray 60 kilos
- Metal galvanized structure and trays for long lasting
- Trays quick locking system



CONTROL UNIT

- Controller R30iB-PLUS
- Intuitive programming
- User-Friendly interface
- Fanuc collaborative functions
- Touchscreen
- Machine utilization reports
- Intelligent maintenance prediction software
- Eccentric loading and unloading mode
- Homing function
- Revolving pallet full handling via software



SAFETY FEATURES

- Fanuc Dual Check Safety System integrated with laser scanner
- Pneumatic or servo-motor driven CNC machine door opener with integrated safety circuit if predisposed

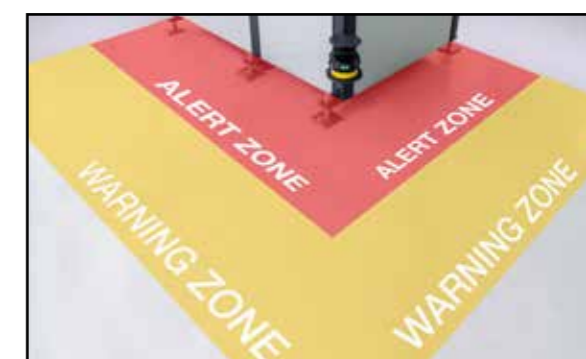

GRIPPER FEATURES (TAILORED ON THE PROJECT)

- 2 Fingers gripper for rectangular shapes
- 3 Fingers gripper for round shapes
- 2 Fingers gripper for long shafts
- Customized gripper for specific shapes
- Air blow system
- Quick change system for gripper
- Low air pressure detection

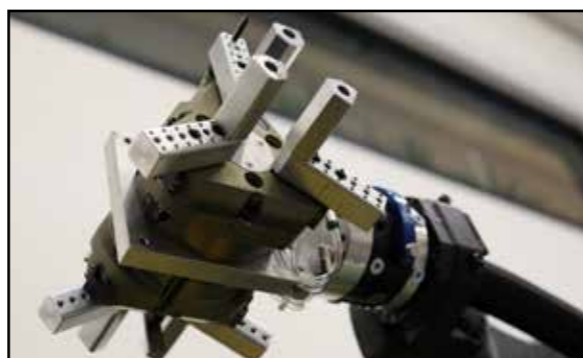

CONNECTION PREDISPOSITION

- Teleservice predisposition
- Predisposition for Industry 4.0 connection



ADDITIONAL WORKING STATIONS

- Parts unloading on box/cage/belt
- Parts positioning on measuring station
- Other tailored customers operations available

